

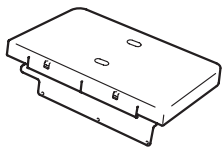
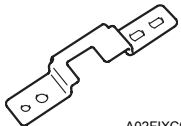

WT-503 Working Table

INSTALLATION MANUAL

Applied Machine: d-Color MF201
 COLOR MFP: 20 ppm
 Product Code: A02F

I. Accessory parts

No.	Name	Shape	Q'ty
1.	Working table	 A02FIXC023DA	1
2.	Mounting bracket	 A02FIXC024DA	2
3.	Screw A (3 × 8 mm)	 A090IXC001DA	4
4.	Screw B (3 × 16 mm)	 9J08IXC075DA	3

WARNING



After unpacking, be sure to get rid of the packaging materials and keep them out of the reach of children.

Putting the head in the plastic bag involves danger of suffocation.

II. Installation procedures

1. Turn off the machine and unplug the power cord from the power outlet.
2. Remove the rear cover (six screws).

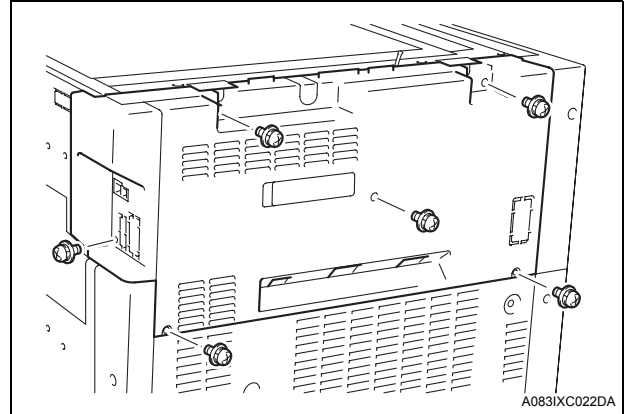

3. Remove the right upper cover from the machine (two screws).

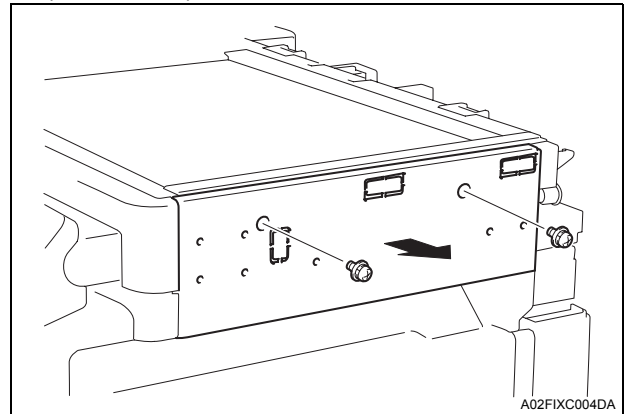

4. Cut out the dividing covers (two places) of the right upper cover that has been removed in step 3 using an appropriate tool such as a nipper.

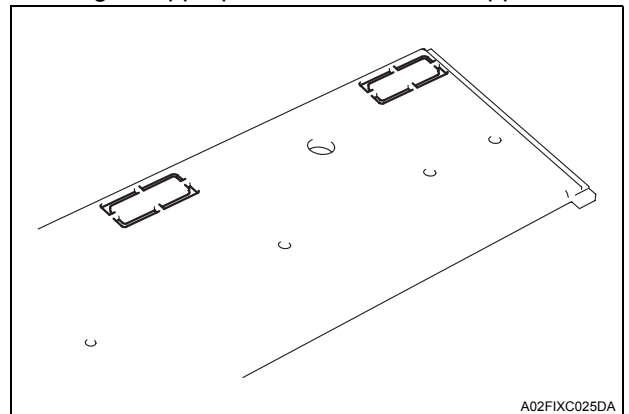

5. Remove the tape shown in the illustration (four places).

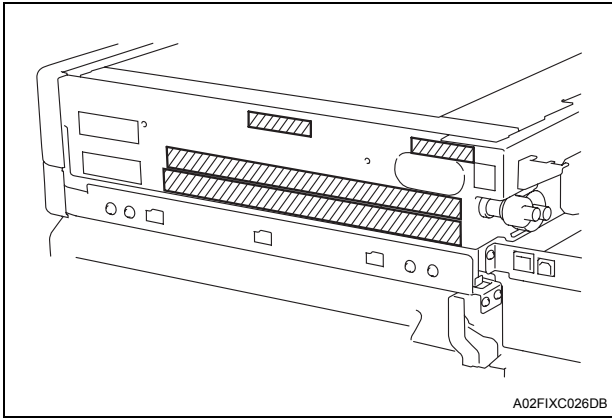

9. Secure the working table (three screw B's furnished with the working table).

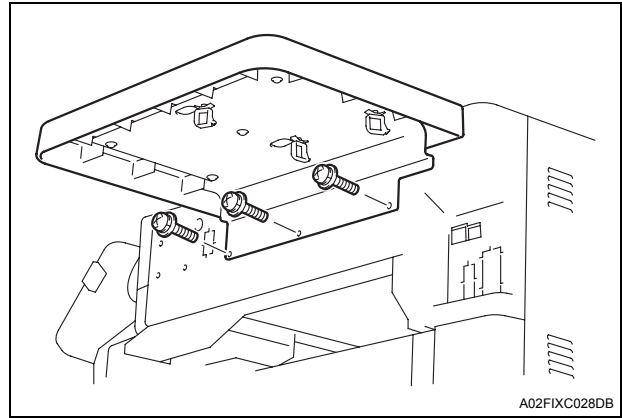

6. Install the mounting bracket (two places) (two screws A each furnished with the working table.)

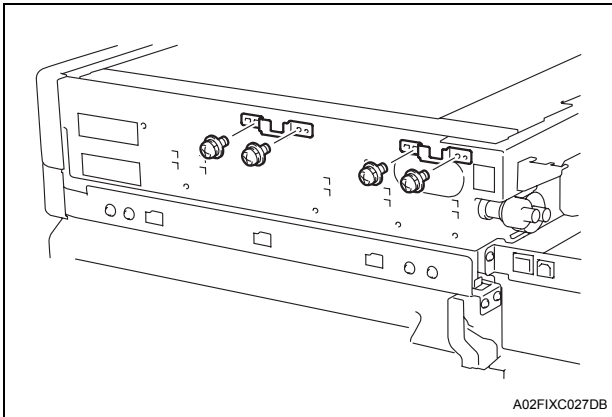

7. Install the removed covers by the inverse procedures to removing them.
8. Insert the snaps of the working table (two places) into the hole position of the mounting bracket and slid it in the direction of an arrow.

